



CD2003GP/GB

FM/AM RADIO IC

1、 Overview

The CD2003GP/GB is a monolithic IC designed for use as a FM/AM radio system.

Combined with audio power amplifier IC, a suitable FM/AM radio can be constituted. Its

features are:

- No need for FM IFT, AM IFT, and FM detector coil
- Adjustment free for FM detector circuit
- Wide operating supply voltage range: $V_{CC}=1.8\sim 7V$ ($T_{amb}=25^{\circ}C$)
- Package: DIP16/SOP16

2、 Block Diagram And Pin Descriptions

2. 1. Block Diagram

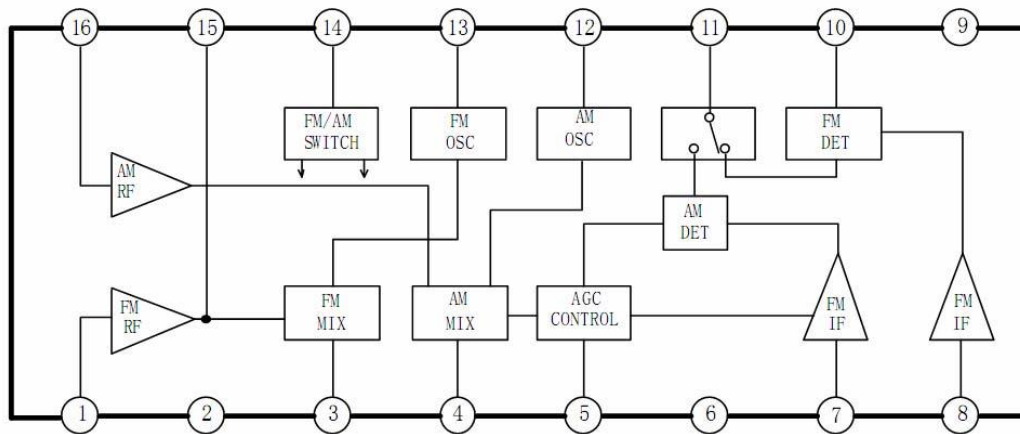

2. 2. Pin Descriptions

PIN	Symbol	Function	PIN	Symbol	Function
1	IN_{FMR}	FM RF Input	9	GND_{OUT}	Output Ground
2	GND_{IN}	Input Ground	10	QUAD	QUAD
3	OUT_{FMM}	FM Mixer Output	11	OUT_{DET}	Detector Output
4	OUT_{AMM}	AM Mixer Output	12	OSC_{AM}	AM Oscillation
5	AGC	AGC Control	13	OSC_{FM}	FM Oscillation
6	V_{CC}	Supply Voltage	14	SW	AM/FM Switch
7	IN_{AMI}	AM IF Input	15	TUN_{FM}	FM Tuner
8	IN_{FMI}	FM IF Input	16	IN_{AMR}	AM RF Input

3. Electrical Characteristics

3.1. Absolute Maximum Ratings ($T_a=25^\circ\text{C}$)

Parameter	Symbol	Conditions	Value	Unit
Supply Voltage	V_{CC}		8	V
Power Dissipation	P_D	DIP16	750	mW
		SOP16	350	
Operating Temperature	T_{amb}		- 25 ~ 75	$^\circ\text{C}$
Storage Temperature	T_{stg}		- 55 ~ 150	$^\circ\text{C}$

NOTE: Derated above $T_{amb}=25^\circ\text{C}$ in the proportion of $6\text{mW}/^\circ\text{C}$ for CD2003GP and of $2.8\text{mW}/^\circ\text{C}$ for CD2003GB.

3.2. Electrical Characteristics

Unless otherwise specified, $T_{amb}=25^\circ\text{C}$, $V_{CC}=3\text{V}$

F/E: $f=98\text{MHz}$, $f_m=1\text{kHz}$

FM IF: $f=10.7\text{MHz}$, $\Delta f=\pm 22.5\text{kHz}$, $f_m=1\text{kHz}$

AM: $f=1\text{MHz}$, $\text{MOD}=30\%$, $f_m=1\text{kHz}$

Parameter	Symbol	Test Conditions	Value			Unit
			Min	Typ	Max	
Supply Current	I_{CCQ}	FM mode, $V_{in}=0$	5.0	10.5	16.5	mA
		AM mode, $V_{in}=0$	3.5	5.0	8.0	
F / E						
Quiescent Sensitivity	Q_s	S/N=30dB		2		μV
Input Limiting Sensitivity	$V_{IN(LIM)}$	V_O 为 -3 dB		2		μV
Local OSC Stop Voltage	$V_{STOP(FM)}$	$V_{in}=0$		1.2		V
Local OSC Voltage	V_{OSC}	$f_{OSC}=108\text{MHZ}$	160	240	320	mV
FM IF						
Input Limiting Sensitivity	$V_{IN(LIM)}$	V_O 为 -3dB	63	112	200	μV
Detector Output Voltage	V_{OD}	$V_{in}=80\text{dBu}$ EMF	75		130	mV
Signal to Noise Ratio	S/N	$V_{in}=80\text{dBu}$ EMF		62		dB

To be continued

continued

Parameter	Symbol	Test Conditions	Value			Unit
			Min	Typ	Max	
Total Harmonic Distortion	THD	$V_{in}=80\text{dBu}$ EMF		0.4		%
AM Rejection Ratio	AMR	$V_{in}=80\text{dBu}$ EMF		33		dB
AM						
Detector Output Voltage 1	V_{OD1}	$V_{in}=27\text{dBu}$ EMF	15		50	mV
Detector Output Voltage 2	V_{OD2}	$V_{in}=60\text{dBu}$ EMF	40	60	100	mV
Signal to Noise Ratio	S/N	$V_{in}=60\text{dBu}$ EMF		43		dB
Total Harmonic Distortion	THD	$V_{in}=60\text{dBu}$ EMF		1		%
Local OSC Stop Voltage	$V_{STO(AM)}$	$V_{in}=0$		1.6		V

4、 Test Circuit

4.1. Test Circuit 1

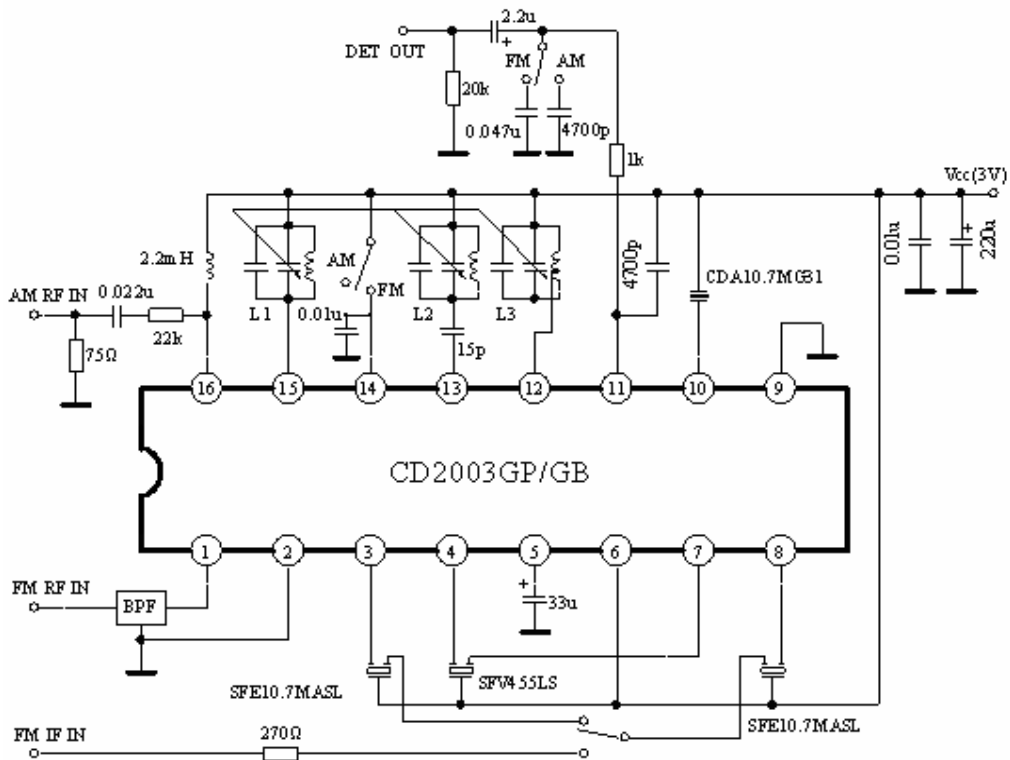

4.2. Test Circuit 2

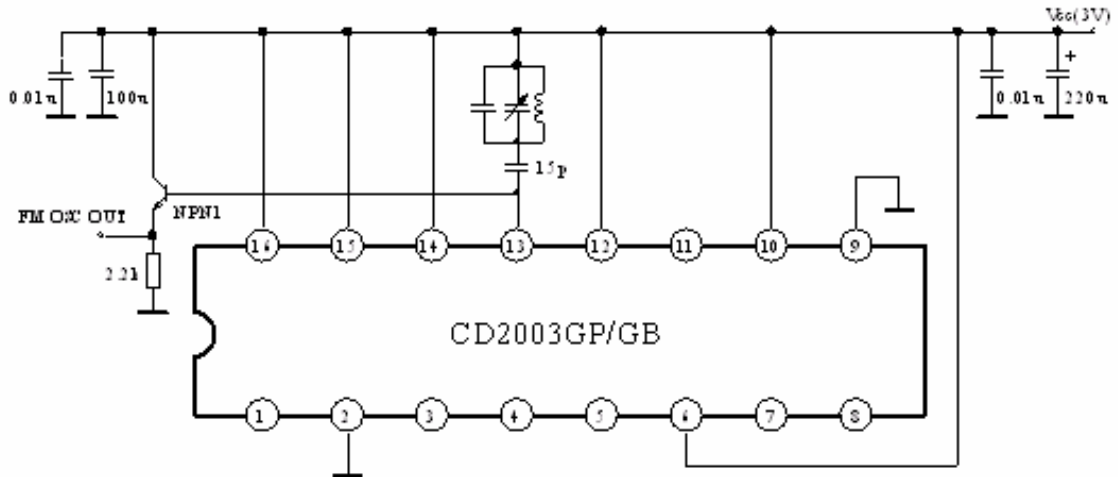

4.3. Note

Coil Data (Test Circuit)

Coil No.	Test Frequency (HZ)	L (uH)	Q _o	C _o (pF)	Turns					Wire (mm)	Reference
					1-2	2-3	1-3	1-4	4-6		
L1: FM RF	100M		100					2.25		0.5	0258-0000-021 (注)
L2: FM OSC	100M		100				1.75			0.5	0258-000-020 (注)
L3: AM OSC	796K	268	125		14	86				0.06	2157-2239-213A (注)

NOTE: SUMIDA ELECTRIC CO., LTD

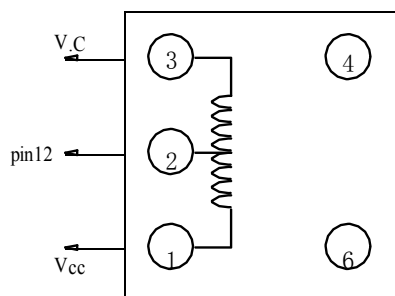

L3

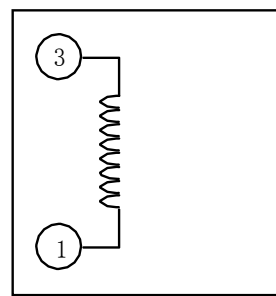

L1 L2

5. Application Circuit

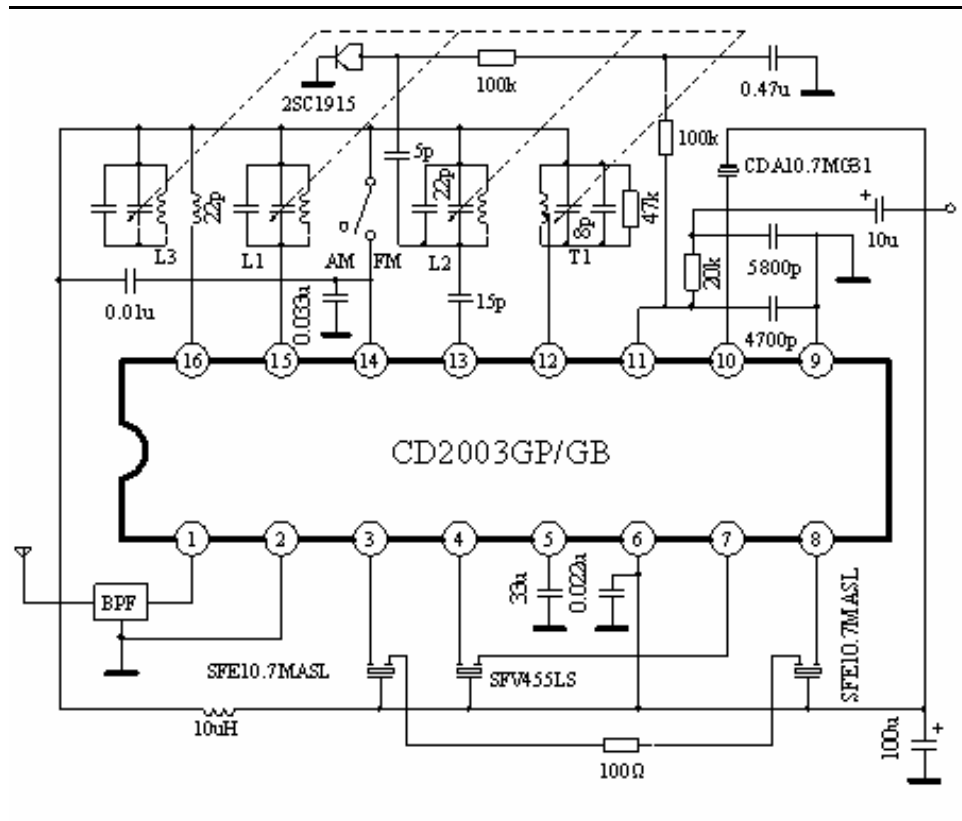

6. Package Outline

6.1. DIP16

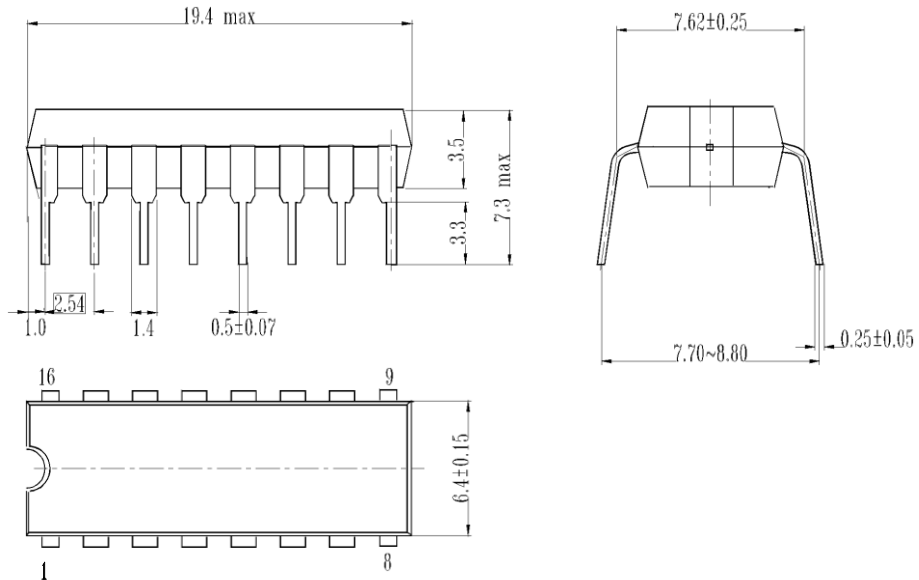



6.2、SOP16

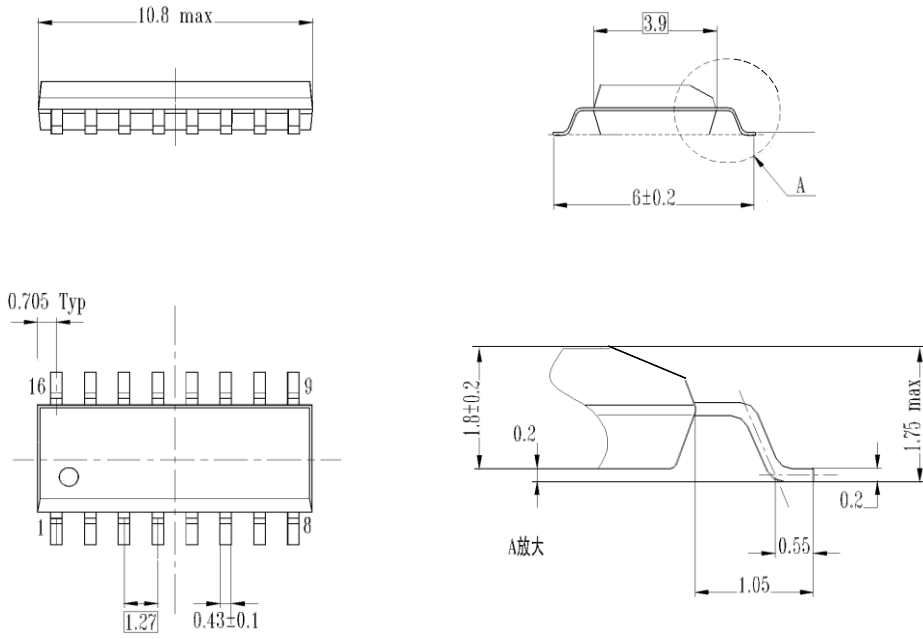

**Note:**

Please read this material carefully before use Semico products;

Wuxi China Resources Semico Co., Ltd. reserves the right to make changes to its products without prior notice, in order to improve design and performance.

Semico assumes no responsibility for or liabilities arising from the specifications listed herein.

Applications described herein are for illustrative purposes only, and Semico makes no warranty that its products will be suitable for the applications specified without further modification.

Semico also assumes no responsibility for the consequences of use of such information nor for any infringement of patents or other rights of third parties which may result from its use. No licence is granted by implication or otherwise under any patent or patent rights of Semico.

Semico does not recommend the use of its products in life support applications where malfunction of such products could be expected to threaten human life. Customers using or selling Semico's products for use in such applications do so at their own risk and shall be liable for all claims or damages resulting from improper use or sales.