

R552 – Nabíj. článěk NiMH 4/5SC 1,2V/2800mAh TINKO, páskové vývody

Specifications

Rechargeable Nickel-Metal Hydride Battery

1. APPLICATION

This specification can be applies to the Sealed Nickel-Metal hydride rechargeable cell or assemble battery:

Model: TINKO-4/5SC2800mAh 1.2V

Single battery type:4/5SC

2、 This specification suits to the cylindrical batteries listed below:

A. Battery norminal voltage: 1.2V.

B. Battery pack voltage can be got by one single cell voltage multiply the quantity of the single cells.

3、 Spacication

The table below can be taken as the basic guideline of evaluation the battery quality.

ITEM	Unit	Specification	Conditions
Nominal Voltage	V/cell	<u>4.8</u>	cell
Nominal Capacity	mAh	<u>2800</u>	Standard Charge/Discharge
Standard Charge	mA	<u>280 (0.1C)</u>	T ₁ = 0~45°C (see Note 1)
	Hour	<u>15</u>	
Quick Charge	mA	<u>840 (0.3 C)</u>	- Δ V=10 ~ 15mV , Environment Temperature 0~45°C -dT/dt=1.0~3.0°C /min
	Hour	4	
Trickle Charge	mA	<u>56-140</u> (0.02C~0.05C)	T ₁ = 0~45°C
Internal Impedance	mΩ / cell	≤25	Fully charged battery, test under 20°C (1KHz)
Discharge Cut-off Voltage	V/cell	<u>1.0v(Standard)</u>	
Quick discharge	mA	<u>2800</u>	Cut off voltage 1.0V/cell, test under -20-60 after narmal charge
Storage Temperature	°C	-20~45	Charge the battery to the full condition of 80%
Typical Weight	g	48	

4. PERFORMANCE

4.1 The battery should be tested with the condition below except special instruction:

Working Temperature: 20±5°C

Relative Humidity: 65±20%

4.2 Caution: Standard charge and discharge condition:

Charge: 280mA (0.1C) × 15hrs

Discharge: 560mA (0.2C) to 1.0V/cell

4.3 Testing facility must conform to the condition:

Voltage meter: IEC 51/IEC 485 stipulated grade 0.5 or above. Resistance more than $10K\Omega/V$
 Ampere meter : IEC 51/IEC 485 stipulated grade 0.5 or above, including the down-lead resistance totally less than 0.01Ω .

BVIR: AC 1KHz sine wave 4 terminals testing equipment.

TESTING ITEM	UNIT	SPECIFICATION	CONDITION	REMARKS
Open circuit voltage	V/cell	≥ 1.25	Test after standard charged and placed for one hour time	
Capacity	mAh	≥ 2800	Standard charge and discharge	Allows 3 times recycling
Discharge at 0.5C	min	Discharge time ≥ 108	Standard charge, then shelve for 60min, discharge at 0.5C to <u>1.0V</u>	
Self-discharge	mAh	Discharge capacity ≥ 1680 60% of nominal capacity	Standard charge, storage for 1 year with the temperature 20°C , and standard discharge	
Constant humidity and hot performance		No damage	Full charge the battery at current 0.5C, $33 \pm 3^{\circ}\text{C}$, $80 \pm 5\% \text{R.H.}$, storage 14 days.	
Vibration		Voltage variety: $\leq 0.02\text{V/cell}$ Internal impedance: $\leq 5 \text{ m}\Omega/\text{cell}$	Charge at current 0.1C for 16hrs, place for 24 hrs, check the battery before and after vibration. Vibration condition: Swing: 1.5mm, Frequency: 3000CPM, Vibrate for 1hr to any direction.	
Fall down test		Voltage variety: $\leq 0.02\text{V/cell}$ Internal impedance: $\leq 5 \text{ m}\Omega/\text{cell}$	Charge at current 0.1C for 16hrs, place for 24 hrs, check the battery before and after fall down test; Impact condition: Fall down from height 1.5m to any direction on the board(Thickness:10mm), test for 3 times	
Over charge		No leakage	Charge at 0.1C for 258days, 0.2C discharge to 1.0V more than 5H	
Safety		No rupture, explosion, but leakage, distortion and package damaged allowed.	Short circuit the battery by the load less than 2Ω after standard charge the battery	
Over discharge		No explode.	Discharge the battery at current 0.2C to 0V, then over discharge the battery at current 1C for 60mins	
Recycling	cycle	≥ 500	IEC standard	Refer to Remarks 1

test(IEC standard)				
--------------------	--	--	--	--

5. Structure, size and marks.

Please refer to the attached diagram.

6. Appearance

There should be no craft, scratch, breakage, dust, color changed, leakage and deformed.

7. WARRANTY

Guarantee time for one year due to the processing and raw material defectiveness.

Suggestion: The products before delivery would be charged 20-80% capacity according to the transportation distance and packing condition. While checking the capacity, please discharge the battery at 0.2C to 1.0V; then charge and discharge the battery at by standard current. If the storage time over 2 months or above, please discharge the battery at the current 0.2C to 1.0V, then charge the battery at 0.1C for 15 hours, after that place for 20mins, discharge the battery at 0.2C to 1.0V. After this activation, check the capacity by the standard current charge and discharge the battery

The first time use suggested to take standard charge method to charge the battery to prevent from damage to battery.

8. CAUTION

- A. Please do not throw into fire or try to open it.
- B. Please do not mix use with other type of batteries or old one.
- C. Please do not discharge the battery at the current exceeds the stipulated one on specification.
- D. Please do not short circuit the battery prevent from permanent damage.
- E. Please do not jointing the batteries.
- F. Please do not reverse load the batteries.
- G. If use the battery at the utmost condition, it could be shorten the battery recycling life, such as utmost temperature, recycling and utmost charge and discharge it.
- H. The battery should be place in cool and dry environment with the charged condition. And should be discharged before mass delivery.
- I. The battery should be stopped using while abnormal happened during working process, please send the battery to the distributor for handling.
- J. Due to the controlled by electrochemistry system, for long time storage situation, suggested to charge the battery to 80%~100% of its capacity.
- K. In order to maintain the battery performance, after storage over 6months, suggest to charge and discharge the battery(Discharge the battery at current 0.2C to 1.2.0V before charge the battery). Then can use or stock it.

Notes:

1. Temperature

2. IEC standard recycling life.

Model	Rechargeable Nickel-Metal Hydride Battery	
Name	TINKO-4/5SC2800	
Nominal Voltage	1.2V	
APPLICATION	280-1400 mA	
Capacity	discharge to 0.1 C to 0.5 V(at20°C)	
	Nominal Capacity :2800mAh	
	Minimum Capacity : 2240mAh	
Dimension	Diameter	22.5--0.7mm
	High	34.0-1m
Charging conditions	Charge at 0.1 C for 16hour (at20°C)	
Quick Charge	560 mA to 1400 mA (0.2C to 0.5C) Stop charge condition: - $\Delta V = 10-15\text{mV/Cell}$ or stop charge when normal capacity = 120 % Max Temperature = 55°C (122° F), T ₁ = 10~45°C	
Internal Impedance	Average internal resistant is 25mΩ when fully charge	
IEC Cycle Life		≥500 times
Weight		48g
Temperature Range	Standard Charge	0°C to 45°C
	Quick Charge	10°C to 45°C
	discharge	-20°C to 50°C
	Storage	-20°C to 35°C

Cycle No.	Charge	Rest	Discharge
1	0.1C × 15h	None	0.25C × 2h20min
2-48	0.25C × 3h10min	None	0.25 × 2h20min
49	0.25C × 3h10min	None	0.25C to 1.0V/ cell
50	0.1C × 15h	1-4h	0.2C to 1.0V/ cell

Repeat 1-50 times recycling, until that the battery discharge time less than 3hrs at the 50 times.

Attaches the graph :

TINKO-4/5SC2800 battery performance

Spacification

Specifications

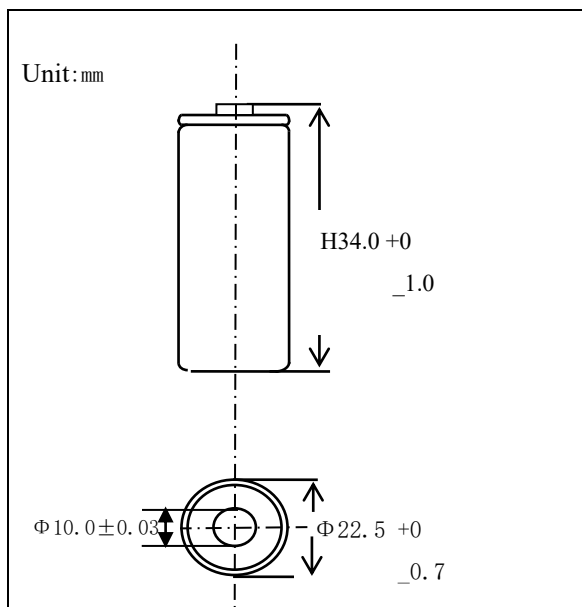

Charging and discharging characteristic

0.2C charge curve

Voltage (V)

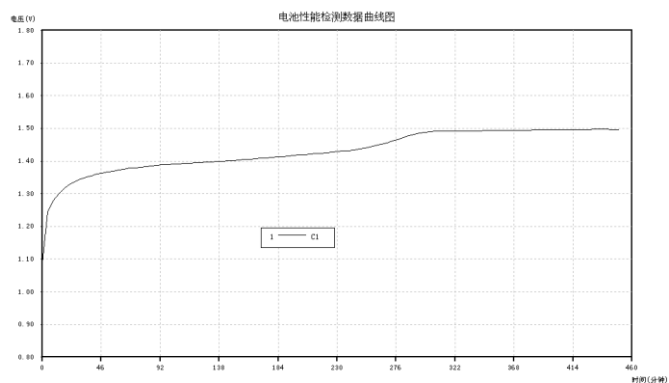

0.2C Discharge curve

Voltage (V)

